INSTALLATION GUIDELINES

Worktops/Table Tops



The following information applies to Teragren's Parquet Butcher Block, Traditional and Strand bamboo worktops ideal for countertops, tabletops, cash wraps and other interior use.

It has been compiled to assist with understanding how basic wood storage, installation and finishing techniques also apply to installing and finishing bamboo countertops, worktops and other interior applications where hardwood products have traditionally been used.

Bamboo, although a grass, reacts like a hardwood, and may be affected by environmental changes. The following basic steps in handling, fabrication and installation are recommended to help avoid or minimize some of the problems associated with wood movement.

HANDLING

Minimize Handling - This is the best way to reduce damage. Plan warehousing and process flow operations accordingly to eliminate excessive handling. Support panels when transporting horizontally to prevent material strains.

STORAGE

Proper stacking - Panels should be stored flat on raised runners of equal thickness. Keep similar lengths of similar products together and maintain proper alignment to avoid bending or flexing panels.

Temperature - Avoid extremes of heat and cold. Panels should be stored indoors. Ideal temperatures fall between 65°F to 75°F.

Moisture - Avoid extremes of humidity. Store away from water and off of concrete flooring. Humidity controls should be installed and maintained to a constant 35% to 55% relative humidity. The storage environment's relative humidity should mimic the anticipated installation environment. Extreme dry climates or environments that are not able to maintain a constant 35% to 55% year-round relative humidity are not appropriate environments. Very damp environments where material will come in contact with extreme moisture or water are also not appropriate for storage.

Light - As with most natural materials, exposure to sunlight may affect the color.

Packaging - In keeping with our high environmental standards, Teragren's packaging utilizes 70 percent recycled content cardboard, recyclable slip sheets, recyclable plastic and water-based ink. The packaging meets strict California environmental standards as stated within the 2006 Toxics in Packaging Prevention Act. Our furniture-grade countertops come individually packaged with a 10 mil wrapping. This recyclable packaging protects material surfaces and maintains the products at a delivered moisture content between 6% to 8%.

ACCLIMATION

Acclimation Goal - To bring the moisture content and temperature of the product into harmony with the fabrication and installation environment.



Note: fabrication of product in an environment with a different relative humidity level than that of the installation environment may result in undesired material dimensional change. *Extreme dry climates or environments that are not able to maintain a constant 35% to 55% year-round relative humidity are not appropriate environments.*

Length of Acclimation - Just as with hardwoods of other species, acclimation time of bamboo will vary with site conditions as well as the width and thickness of the bamboo. Acclimation should match the installation environment or allowances should be made for acclimation to the installed site. 72 hours is considered a minimum.

Additional acclimation may be necessary if products have newly exposed edges due to cutting and shaping. In extremely dry climates without relative humidity controls, acclimation of thick material such as a 1.5" counter or table top, may take longer than expected. Material may change dimensionally or warp especially if acclimation is uneven and exposed to extreme humidity or temperature changes. If left to acclimate too long, material may dry and crack.

Acclimation Methods - Packaging must be completely removed. Keep material off of concrete flooring, away from the elements, open doors, or windows. Material should be acclimated off the floor and stacked flat, with equal-size stickers being placed between each additional sheet to allow for even air-flow and temperature over both the top and bottom surface of the product. Stickers should be placed in sufficient quantity to ensure all products are evenly supported. Note: Place a sheet of MDF or other material equal to or larger than the product acclimating as the final stickered layer.

FABRICATION + INSTALLATION

Every project is unique and considerations for fabrication should be made based on the region(s) in which the project is both being built and installed. The following are guidelines to consider:

Environment - The fabrication environment should match the installation environment. Do not deliver, fabricate, or install product until Heating, Ventilation, and Cooling (HVAC) systems are on-line and functioning. Extreme dry climates or environments that are not able to maintain a constant 35% to 55% year-round relative humidity are not appropriate environments.

Expansion and contraction precautions - Like hardwoods, Teragren standard bamboo and strand products are kiln dried and manufactured to achieve a moisture content of 6% to 8%. Bamboo, like hardwood, will undergo dimensional changes when exposed to high or low relative humidity. The wider the panel, the greater the change. Allowance for expansion and contraction must be incorporated into the design and installation of the product. End grain panels may expand or contract as much as 3/4". When laminating bamboo materials to a substrate of a different material such as MDF, the expansion and contraction properties of the substrate must be considered. Substrates need to acclimate in the same fabrication environment as the bamboo prior to laminating.



Important Note: Without a means to expand and contract, bamboo, like hardwood, will crack under the stress. Oversized expansion slots, panel clips and floating panel construction applications are the most appropriate installation methods. In installations abutting ceramic or stone tiles, using a flexible caulk to allow for expansion is recommended. Because bamboo is very strong, unforeseen expansion could damage surrounding material. When appropriate, vapor and or heat barriers should be incorporated into the design to avoid temperature or moisture extremes that can affect the panels adversely.

Moisture Permeability - The best practice is to finish one side just like the other. Stain and topcoat systems change the surface permeability just like paint. Unequal treatments can cause for one side to absorb or lose more moisture.



The application of countertops directly over concrete, or any substrate that is wet or unfinished, (especially when combined with nailing, screwing or gluing the countertops in place) may lead to failure. The countertop is unbalanced and constrained.

The rule - Whatever is chosen as a sealer or finish for the top to monitor moisture permeability, the same treatment and number of coats needs to be applied to the underside to provide for a balanced panel.

Cutting and Tooling - Bamboo cuts and tools well with standard woodworking tools. Sharp carbide tipped tools are recommended to help prevent tear-outs. When cross-cutting, the higher the saw tooth count the better, especially with Teragren's Strand bamboo panel products. A very high ATB blade works best. Bamboo machines easily with the grain.

Just as plywood, bamboo can splinter when crosscutting, coping and tenoning across the end grain. Due to the linear fibrous nature of bamboo, do not try to snap off small pieces - cut them or sand off. Pulling bamboo fibers could cause them to 'run' along the length of the grain. Profiles can be easily routed. Bamboo sands well with any standard woodworking sander.



Fastening - Pilot holes, pre-drilling, oversized slots for screw inserts, panel clips or other methods that allow for expansion and contraction are necessary for unrestrained applications and countertops. Nailing, screwing down tightly or gluing panels in place are methods which do not allow inherent movement and have a high risk of failure.

Adhesives - Most common woodworking adhesives suitable to the cabinet and furniture manufacturing industry have been used successfully and can be recommended such as polyvinyl acetates (PVA) glue and aliphatic resin glue (yellow glue). Contact cement is not a preferred adhesive for wood or bamboo products of thickness other than veneer. High water content in some adhesives may introduce moisture imbalances that react with finish applications.

Please note that the adhesive used to manufacture most of our products, other than the parquet end grain butcher block and Vertical Grain Countertops are not food grade. If the surface is to be used for food preparation, a food grade sealer is recommended. Or ask which of our panels and veneer are available or may be special ordered with formaldehyde free- food safe adhesive.

Cut-Outs and Cut-offs - If acclimation has not been completed, cut-outs and cut-offs may release material stress causing warping or cracking. Additional acclimation may be required should this occur. Cut edges need to have a finish applied to prevent possible cracking.

Heat Tolerance - As with any hardwood, bamboo can be damaged by sudden and rapid temperature changes. Applying an aluminum heat reflective tape with attached insulation will help dissipate heat and allow for a more even expansion and contraction to areas subject to this exposure such as cook tops. Regardless of the type of finish applies, hot pots and pans should never be directly placed on the surface. A hot pad or trivet should be placed on the surface for protection.

Cuts and Scratches - As with standard wood countertops, the surface may be sanded and re-finished. The choice of finish applied will provide various qualities of protection and durability. Tabletops or countertops intended to be used as cutting surfaces should be finished with a food safe finish, such as a mineral oil. This type of finish will, over time, show cuts, scratches and stains and may be sanded and re-finished. Hard surface finishes are optimum for ease of care, such as wiping up spills, however care needs to be taken to protect against cuts and scratches. Surface protection such as cutting boards, coasters, trivets or pads will protect and extend the beauty of a finish.

Use Around Sinks and Tubs - Give extra care and attention to sealing edges when panels and countertops are to be used around sinks or tubs. Prolonged or constant exposure to water can cause darkening of the wood and over-saturation that in turn causes warping. Teragren recommends installing a non-porous material such as stainless steel or tile as a transition to the bamboo.

Checking - This condition is caused by the contraction of the butt ends and not that of the center part of the panel. It could be a sign that your environment is too dry or the panel was not properly sealed. Determine what the relative humidity is and make proper adjustments. These cracks should be filled promptly with wood filler, sanded smooth, and finished with a protective finish. Split ends can also be caused by not allowing for expansion and contraction when attaching items to the panel. Relieve tension at once by removing screws and repair splits as suggested above.

FINISHING

Finishes enhance the beauty and extend the useful life of bamboo as with hardwood. Bamboo takes a sealer and finish very well. Finishes and adhesives suitable to the cabinet and furniture manufacturing industries have been used successfully with bamboo. Teragren furniture grade panels are unfinished, sanded to 180 grit on both front and back faces as are unfinished countertops. Additional sanding prior to finishing is always recommended. All panel surfaces should be inspected for any fissures or imperfections prior to applying finish applications. Strand bamboo has a wood-like grain with natural fissures. The application of a finish will highlight fissures or imperfections that were not previously apparent. Additional sanding and/or filling between finish coats will result in a higher level of finish quality.



All Surfaces should receive a finish, including edges, ends, cutouts and bottom side. At least three to four coats are required for full absorption. End grain absorbs sealers and needs to be applied multiple times to seal thoroughly and be effective. Equal applications of sealer and finish are recommended to allow for slow balancing. For example, if two full coats are applied to a top face, two full coats of the same finish should be applied to the back face.

Left unfinished, the panels can either absorb moisture or dry out. Moisture imbalance will cause cracking. Any new cuts need to be re-sealed. Sealers and finishes need to dry thoroughly between applications and where the relative humidity of 40% to 60% year-round is present. The longer a panel remains unfinished and the greater the environmental extremes, the greater the chance the panel will develop problems. This is natural and site condition material response and is not considered a manufacturing defect.

Finish Selection for unfinished panels or countertops

Different finishes offer varying degrees of protection, durability, ease of application, repair- ability and aesthetics. No single finish excels in all categories. A finish that excels in one may fail in another. In choosing a finish you must accept trade-offs based on the qualities of wood protection and durability for the intended use. Water-repellent finishes will reduce the effects of brief periods of moisture (washing) and liquids, making the material easier to clean. Finished wood countertops are less likely to show stains. For information on the safety and toxicity of any finish, check the label and/or contact the manufacturer of the finish.

Testing for stain and finish results is always recommended. When applying finishes, follow manufacturer's suggested temperature and thickness for application. Testing the adhesion or finish to ensure the overall compatibility between the treatment, the panel, and the installed environment is recommended.

Note: Independent U.S. testing was performed to ensure the adhesive between the bamboo slats on Teragren products are compatible with Methyl Alcohol and Methyl Ethyl Ketone-based finishing products.

TERAGREN PRE-FINISHED COUNTERTOPS - MINERAL OIL/BEESWAX

Mineral oil/beeswax is a food and environmentally safe finish. This allows for the top to be used as a cutting surface and for easy-care. Reapplication of readily available mineral oil or one of many commercial blends is needed to maintain the bamboo's moisture balance and prevent it from drying out excessively. **Reapplication during the first year is recommended monthly or twice monthly depending on your site conditions**; then every 4 to 5 months as needed, depending on use and cleaning. Constant wetting /drying causes bamboo, like wood, to dry out, warp, check and craze.

Tabletop and Worktop Support - Full support is recommended. Panels and butcher block have not been tested for weight tolerances. Installation of a ¾" plywood base to support tabletops or countertops is suggested. Where full support is not present (e.g. pedestal tables with a 12" center plate support), one-inch plywood is required. 36" is the maximum diameter recommended for pedestal tabletop. Cantilevered cabinet or island applications of more than 12" must have a brace support. A maximum of 6" overhang is recommended without plywood support.



Allowance for expansion and contraction of tabletops and countertops is required. All tabletops and countertops should be attached to bases on, or at least near, all four corners. Very large tops may require more mounts. We do not recommend setting the countertop with non-flexible adhesive caulk.

Most cabinet manufacturers provide corner blocks within the cabinet for attaching the countertop to the cabinet base. Pilot holes should be predrilled through the corner blocks into the underside of the top.

Securely fasten the countertop to the base unit with appropriate length wood screws or ¼" lag bolts. The top should be attached in each corner; additional attachments may be desired at three places across the width (on the front edge, the middle, and at the back edge) at approximately 12" intervals throughout the length of the top.

Using a 3/8 inch drill bit, drill a hole in the center of each of the four corner blocks. Rock the drill back and forth in the hole to elongate it in the direction perpendicular to the grain of the countertop. If your counter top is deeper than 36 inches you should drill two 3/8" holes right next to each other and use a jig saw to cut out between them making a slot.

Adjust your counter top on the base to even up the reveal all the way around. Drill pilot holes from underneath the counter through your slotted holes into the countertop making sure not to drill through the top. Use a washer on the lag bolt and drive the bolt snug.

Where it is not possible to attach the countertop to a cabinet base using corner blocks, attach several angle irons to the underside of the countertop and to the inside of the cabinet casework, as close as possible to the corners. Where the top does not rest on a cabinet, it must be supported by strips of wood. If your top contains multiple pieces, ensure the corner fittings have been tightened after the top has been installed. Be sure to allow for expansion and contraction of the countertop.

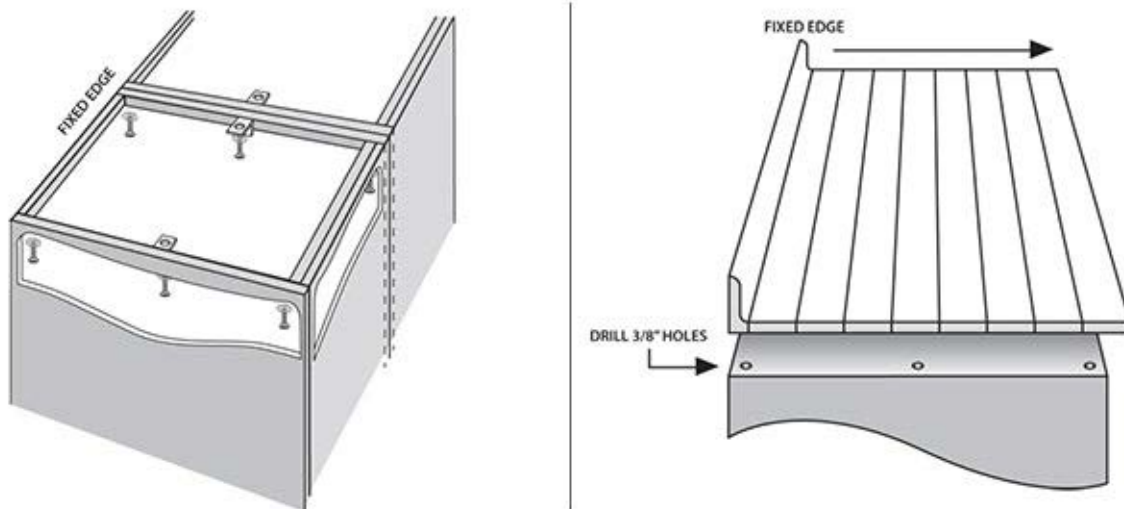

Some manufacturers of cabinets and appliances take into consideration expansion and contraction by slotting the screw holes. If your pilot holes are drilled at the extreme ends of the slots and the block expands or contracts, you negate the advantage of the slots. Where a manufacturer has not made such allowances, you should use an undersized screw with a washer or make the cabinet screw holes oversized (3/8" larger in diameter than the screw) using a flat (countersunk) head screw and a large washer. Do not over tighten the screws as this will restrict the natural movement of the top. Larger panels may expand or contract as much as 1/2". Here again, the rule of thumb is the bigger the block, the greater the expansion.

Back Splash - The back splash is usually attached to the wall surface, not to the countertop back edge against the back wall. Caulking the bottom edge to the countertop is recommended to prevent water from penetrating and potentially damaging the countertop and walls. Flexible caulking is recommended.

COLOR

Color variation is an inherent part of all natural materials, including bamboo. Natural color variations will be apparent, not only from slat to slat, but from panel to panel. As with hardwoods, dark tones (caramelized bamboo) will tend to lighten over time. Lighter tones (such as natural bamboo) tend to darken over time. Exposure and duration of UV light will determine how extreme and how quickly changes may occur. Teragren's color grading standards in the manufacturing process ensure consistency of color and quality.

Due to varying application environments and situations, these guidelines do not guarantee results and should be used as a supplemental source of information only. Teragren is not responsible for any costs or expenses incurred during installation or removal of defective pieces due to warping, splitting or any other reasons. Please review our Product Specifications and Material Safety Data Sheets for further information.

For more information about relative humidity and its relationship to moisture content, please reference the Architectural Woodwork Institute (AWI) website at www.awinet.org and the Hardwood Plywood and Veneer Association (HPVA) website at www.hpva.org.

Contact your Teragren distributor or retailer for more information or [email tech support](mailto:tech@teragren.com).



FINE BAMBOO FLOORING, PANELS & WORKTOPS